

# RS-800

## Carbon-brush motors

Application : Drill & Screwdriver

用途：電動工具

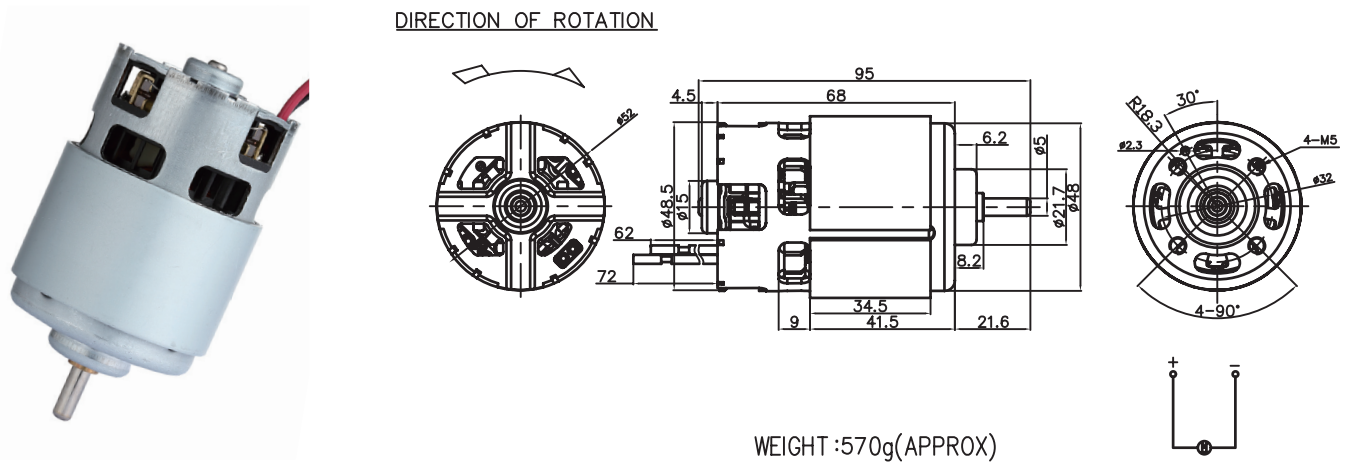

MODEL	VOLTAGE		NO LOAD		AT MAXIMUM EFFICIENCY					STALL			
	OPERATING RANGE	NOMNAL	SPEED rpm	CURRENT A	SPEED rpm	CURRENT A	TORQUE g-cm	TORQUE mN-m	OUTPUT W	EFF %	CURRENT A	TORQUE g-cm	TORQUE mN-m
REB-8P11P37-8508F-R	12.0-24.0	21.0V CONSTANT	23000	5.00	19455	36.31	3005	294.61	600.38	81	309.17	28389	2783.24
REB-8S11P37-3740F-R	12.0-24.0	24.0V CONSTANT	3800	1.40	3258	6.72	3502	343.33	117.17	75	44.98	27449	2691.08

馬達的出軸長度及性能參數，EMC 對策可依客人要求做調整，詳情可詢問相關業務人員。  
Please inquire your sales representative for output, performance and EMC solution.

