

Application : Drill & Screwdriver 、 Electric gate 、 Lawn Mower 、 Suction pool cleaner

用途：電動工具、電動門、智能割草機、水底吸塵機

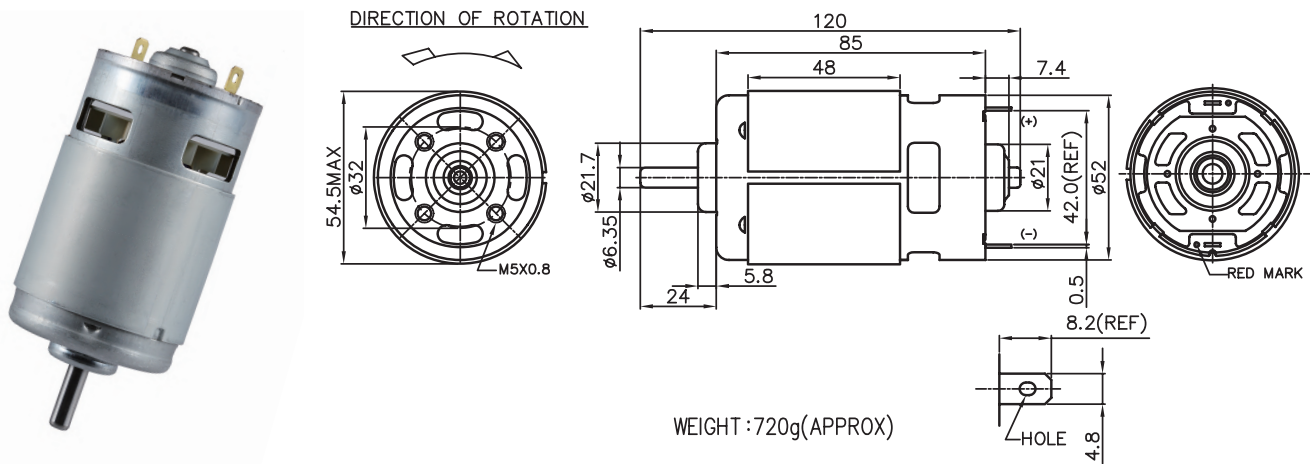

| MODEL | VOLTAGE | | NO LOAD | | AT MAXIMUM EFFICIENCY | | | | | STALL | | | |
|-----------------|-----------------|----------------|--------------|--------------|-----------------------|--------------|----------------|----------------|----------|-------|--------------|----------------|----------------|
| | OPERATING RANGE | NOMINAL | SPEED rpm | CURRENT A | SPEED rpm | CURRENT A | TORQUE g-cm | OUTPUT mN-m | EFF W | % | CURRENT A | TORQUE g-cm | TORQUE mN-m |
| 997-5036-R | 18.0 - 48.0 | 24.0V CONSTANT | 4900 | 0.42 | 4198 | 2.79 | 1197 | 117.35 | 51.60 | 79.67 | 25.95 | 12350 | 1211 |
| 997-7018-R | 6.0 - 36.0 | 12.0V CONSTANT | 4900 | 1.40 | 4182 | 5.40 | 1168 | 114.51 | 50.16 | 78.44 | 48.12 | 11499 | 1127 |
| 997-5030-RC-NF | 12.0 - 36.0 | 24.0V CONSTANT | 5800 | 0.65 | 5165 | 2.84 | 1022 | 100.20 | 54.21 | 80.00 | 26.65 | 10623 | 1041 |
| 997B-5015x2TF-R | 24.0 - 40.0 | 40.0V CONSTANT | 19500 | 2.50 | 17361 | 13.94 | 2634 | 258.24 | 469.62 | 85.00 | 110.79 | 23373 | 2291 |

馬達的出軸長度及性能參數，EMC 對策可依客人要求做調整，詳情可詢問相關業務人員。
Please inquire your sales representative for output, performance and EMC solution.

